



## Model LM OG-I-SS / LM OG-TI-SS for industrial applications



### Features LM OG-I-SS

- Leakproof, magnetic drive
- Large LCD Display
- One decimal point precision
- Push button calibration
- Totalization in gallons or liters
- Delivery in pints, quarts, liters or gallons
- Only two parts to reduce maintenance costs
- Accuracy to  $\pm 0.3\%$
- Minimum three year battery life
- Low battery indicator
- Replaceable battery
- Battery shelf life – 10 years
- Humidity and moisture resistant register
- Two year limited warranty
- Not for use in Ex-zone

### Description LM OG-I-SS

The electronic register module contains a microprocessor board powered by a lithium battery with an expected life of 3 to 5 years depending on use. It can be programmed to dispense in pints, quarts, liters, or gallons and will totalize in liters or gallons. A calibration factor and unit of measure are programmed during factory test. Unlike mechanical meters, these units can be electronically recalibrated in the field when necessary. A 5-digit liquid crystal display, accurate to the second decimal place, shows the exact amount of fluid dispensed. The entire register module is protected from the wear and tear of normal shop use by a rugged, glass filled, shock resistant, nylon housing.

### Description LM OG-TI-SS

The stainless steel meter with pulse transmitter, model LM OG-TI, is an economical, rugged yet accurate meter. The transmitter, mounted on the meter, can be wired to batch controllers, remote counters and other electronically operated instruments that can accept pulses from a reed switch, and have scaling capabilities. The oval gear transmitter is contained in a glass filled plastic housing with a NEMA 4X rating.

### Applications

The electronic meter is designed to dispense industrial fluids.

### Features LM OG-TI-SS

- Does not require external power
- Rugged, corrosion resistant stainless steel enclosure
- Watertight, NEMA 4X housing
- Compatible with most flow controllers and counters with scaling capabilities
- Humidity and moisture resistant transmitter
- Maximum operating pressure 100 bar
- For use in Ex-zone 1 (with suitable drive)

### Operation

As fluid passes through the metering chamber by entering the inlet port, it forces the internal gears to rotate and exits through the outlet port. Each rotation of the gear displaces a given volume of fluid. Controlled clearances between the gears and chamber wall insure minimum leakage. As the gears rotate, a magnet on each end of the gear activates the microprocessor in the register. Depressing the RESET button before each use resets the totalizer to zero. Squeezing the trigger handle dispenses the fluid. The total amount of fluid dispensed from inventory can be checked periodically by depressing the TOTAL button. If the units dispensed are pints, quarts, or gallons, the totalizer will read in gallons. If the units dispensed are liters, the totalizer will read in liters. Caution: The use of meters in applications other than those described in this bulletin may result in inaccuracy and possible meter failure.

### Dimensions (mm)

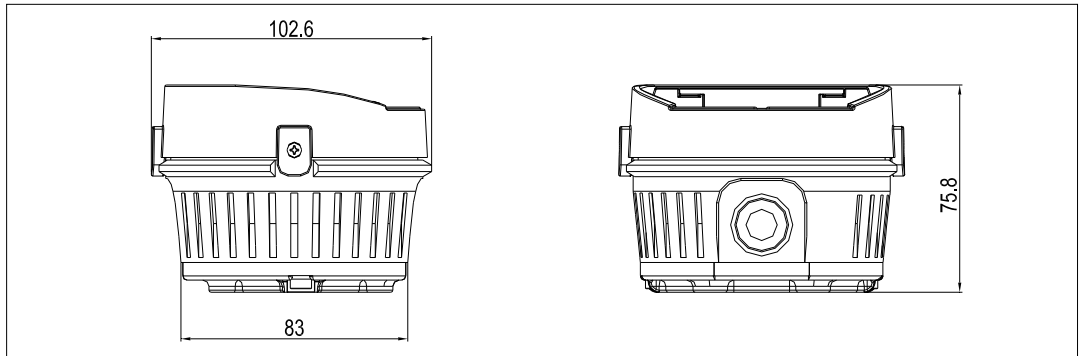

### Technical data

Type	LM OG-I SS	LM OG-TI
Flow rate	0,5 - 35 l/min	
Operating pressure	0,35 - 100 bar	
Operating temperature	-20°C to +80°C	
Accuracy	±0.5%	
Weight, less handle	1,5 kg	0.9 kg
Pulses per liter	-	100
Display	5-digit LCD display, 5/16" high (8 mm)	
Inlet & outlet connections	½" BSPP	

\* Tested with Mobil DTE-25 motor oil at ambient temperature. Min./max. flow rates will vary with fluid viscosity.

### Materials

Type	LM OG-I SS	LM OG-TI-SS
Housing	Stainless steel 1.4301	Stainless steel 1.4301
Oval gear meters	Vectra (LCP-plastic)	LCP (Liquid Crystal Polymer)
Pulse housing		Fiber-glass reinforced Nylon
O-ring	Viton (Kalrez optional)	Viton

### Oval gear pressure drop vs flow rate for various fluids

Viscosities in centistokes (11-19-96)

